A large, faint watermark of the Jupiter logo is centered on the page. It features a circular border with the word 'JUPITER' and the number '4' inside, rendered in a light blue, semi-transparent style.

3rd Workshop
IEAGHG Oxy Fuel Network
Yokohama, Japan
March 5th and 6th 2008

Brian R. Patrick
Director of Development
Jupiter Oxygen Corporation (USA)
www.jupiteroxygen.com

Keys for Carbon Capture Technology

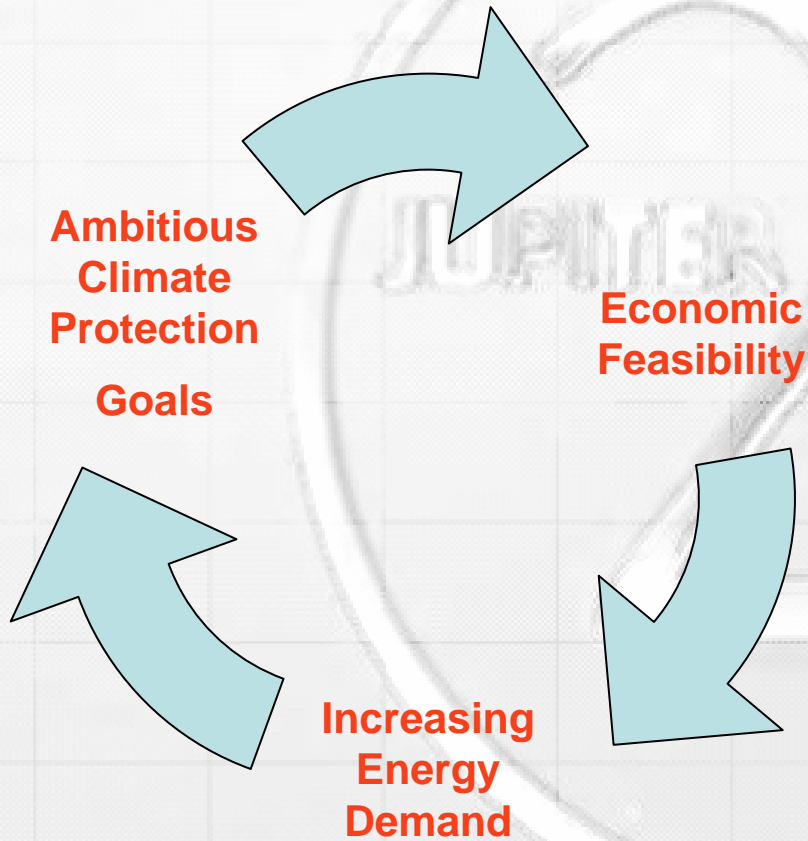

→ Key for successful carbon capture technology development:

- Reduce parasitic power losses associated with carbon capture
- Use cost effective technology for carbon capture
- Create a practical approach for retrofits
- Design a truly CO₂ capture ready concept

Jupiter Oxygen – Hammond Indiana 15 MWth Test Facility



JOC OXY-FUEL IPR* CLEAN COAL POWER GENERATION

*Integrated Pollutant Removal (IPR) System, NETL US DOE

AIR SEPEARATION UNIT

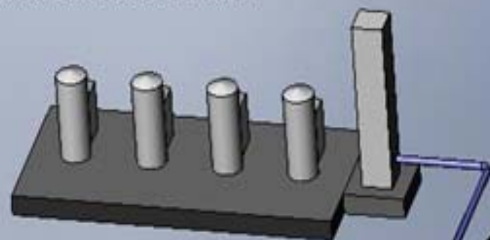

COAL SUPPLY



POWER GENERATION



OXYGEN SUPPLY

COAL PULVERIZER

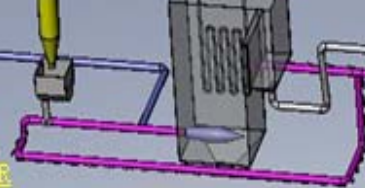

OXY-FUEL BURNER & FLAME

FLUE GAS RECIRCULATION

IPR SYSTEM – CO2 COMPRESSION TRAIN

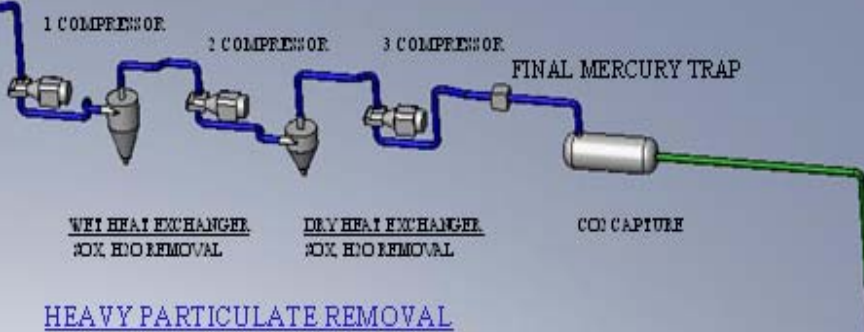

HEAVY PARTICULATE REMOVAL
PM REMOVAL - MERCURY REMOVAL

CO2 PIPELINE

CO2 – UNDERGROUND STORAGE AND USE

- SPECIFIC GEOLOGICAL FORMATIONS
- ENHANCED OIL/NATURAL GAS RECOVERY



JUPITER OXYGEN CORPORATION

15 MWth Oxy-Fuel Test Facility - Hammond, Indiana

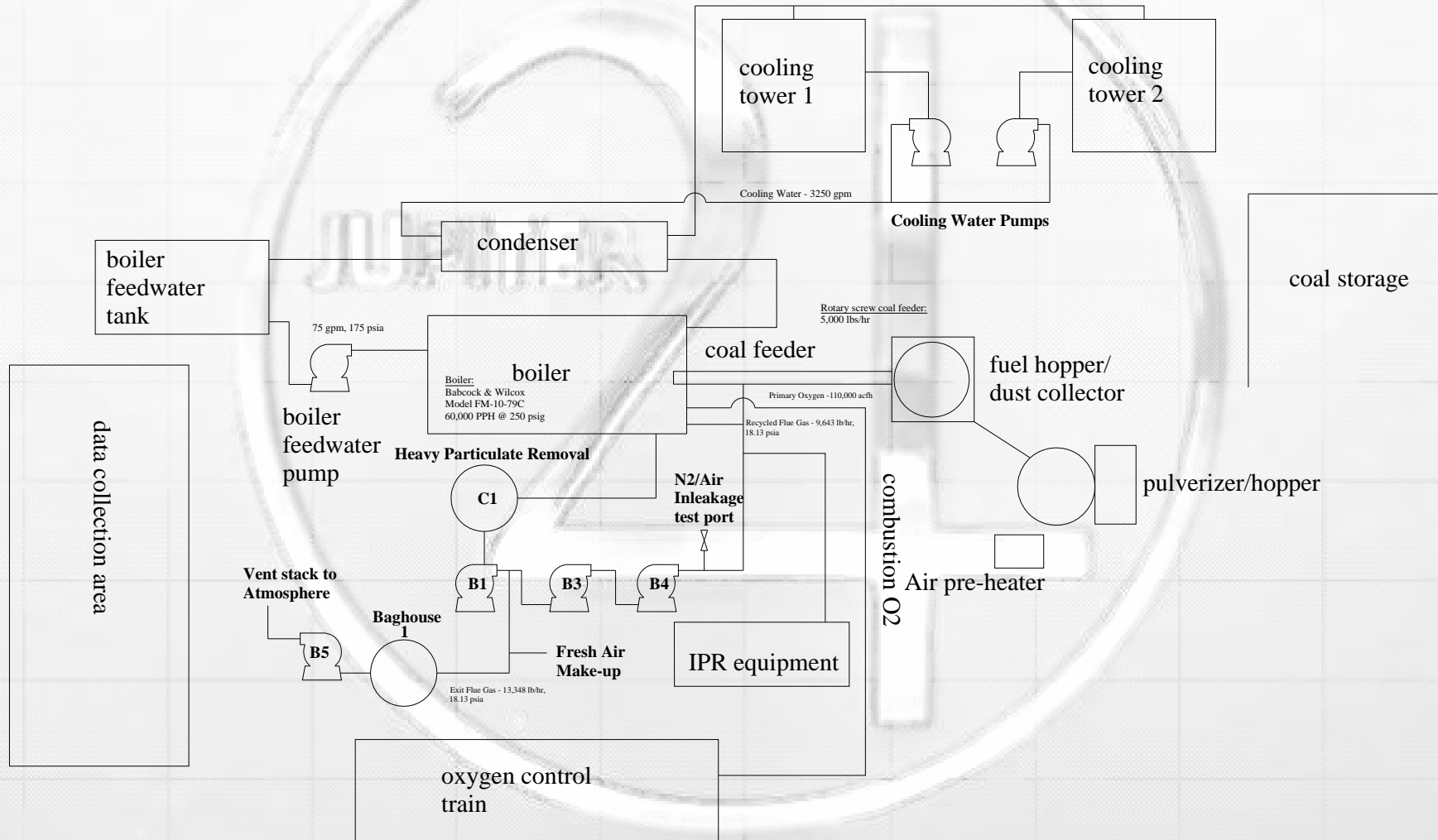

Boiler PID Loop

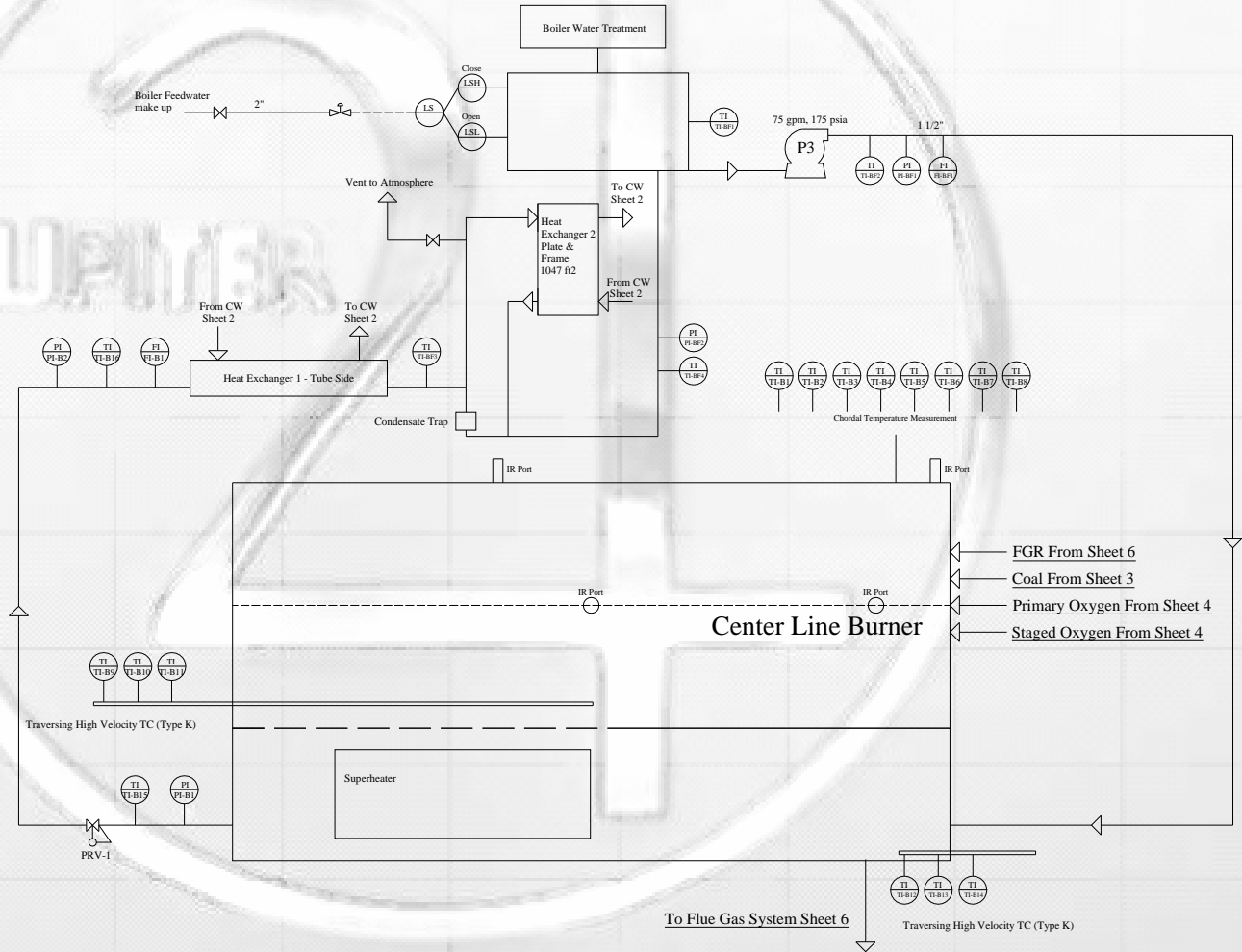
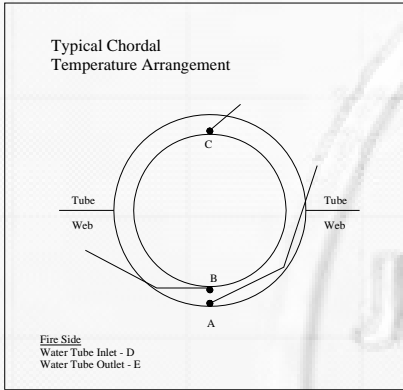

15 MWth Boiler Front View

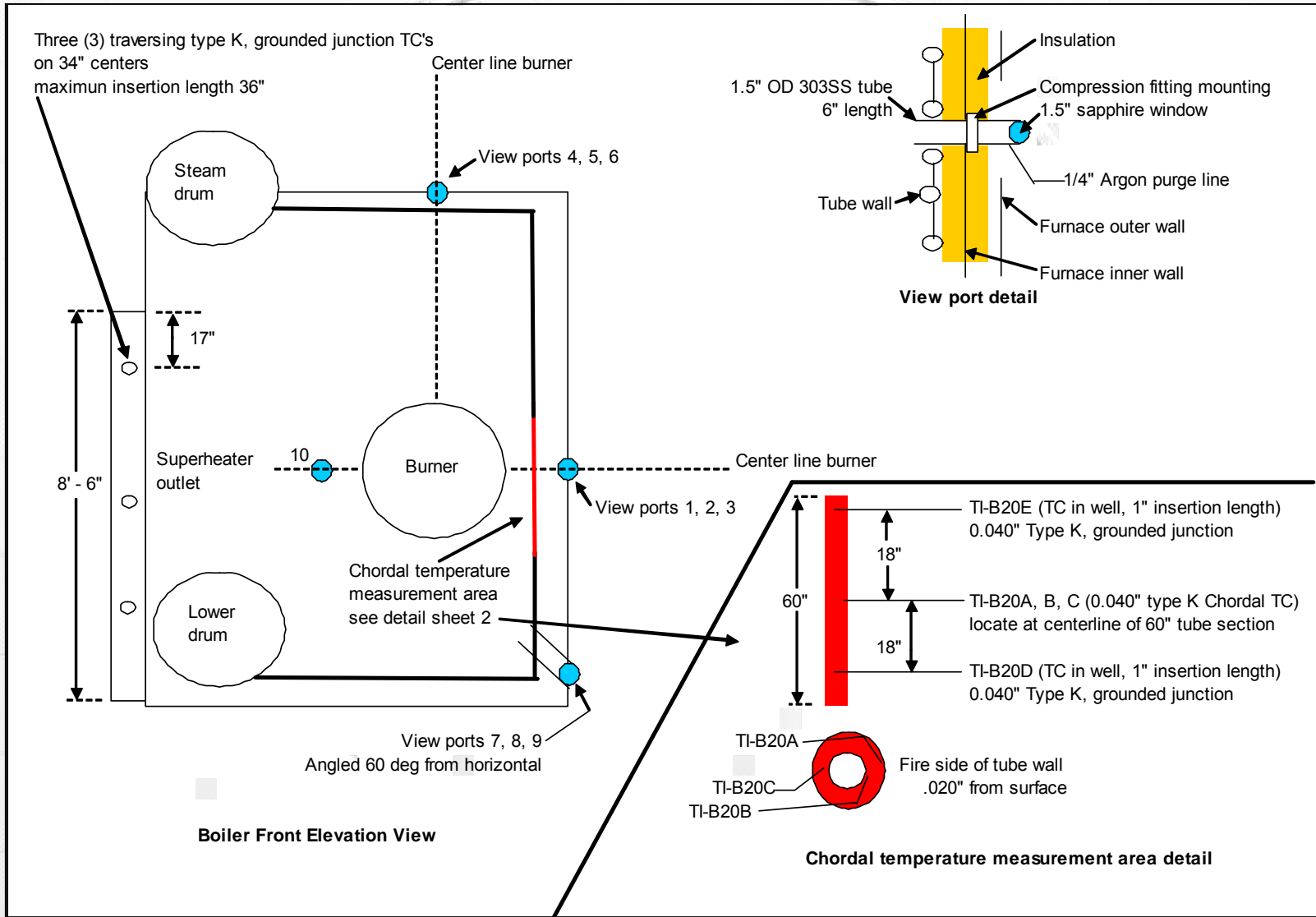

Flue Gas Recirculation

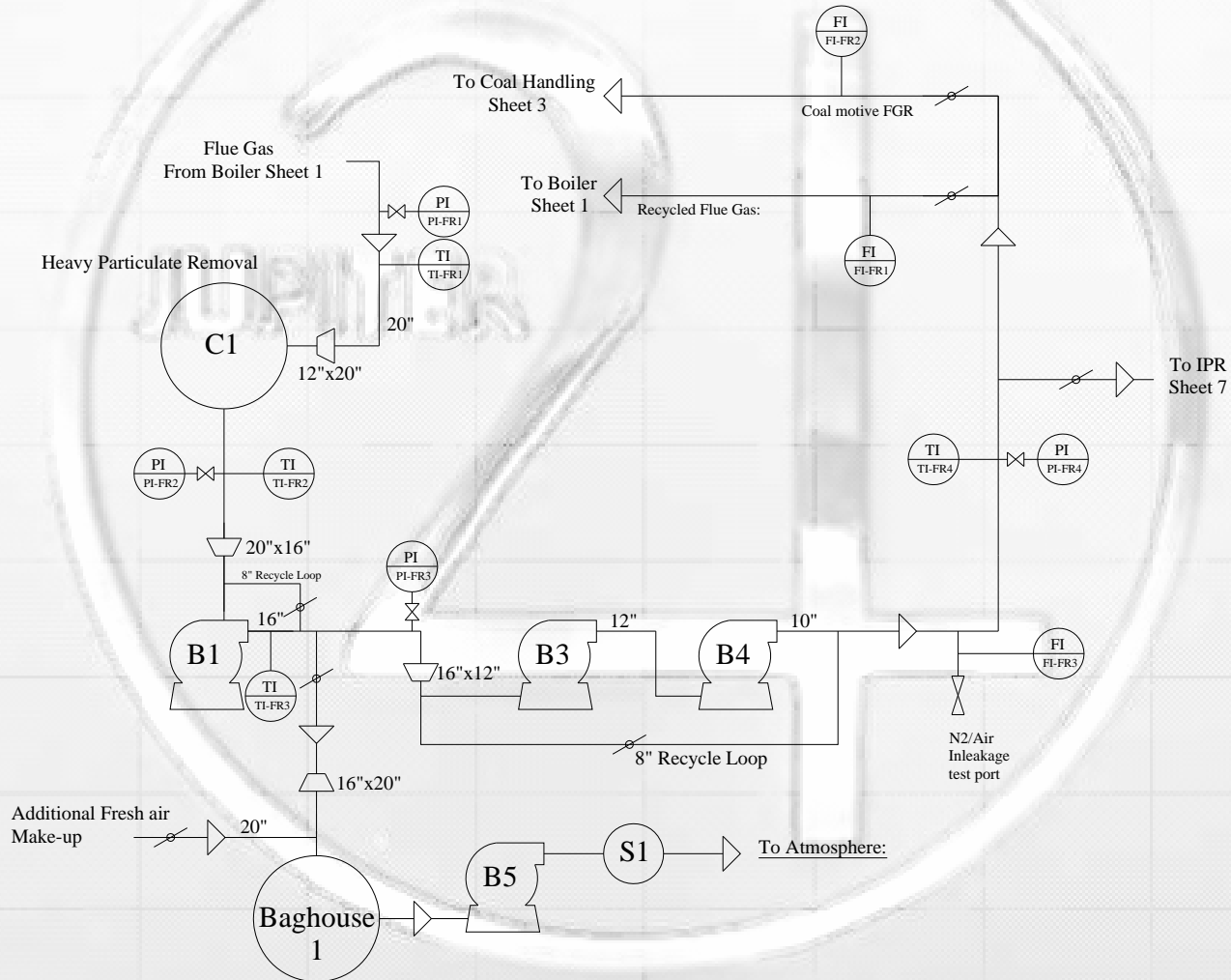

Cooling Tower Loop

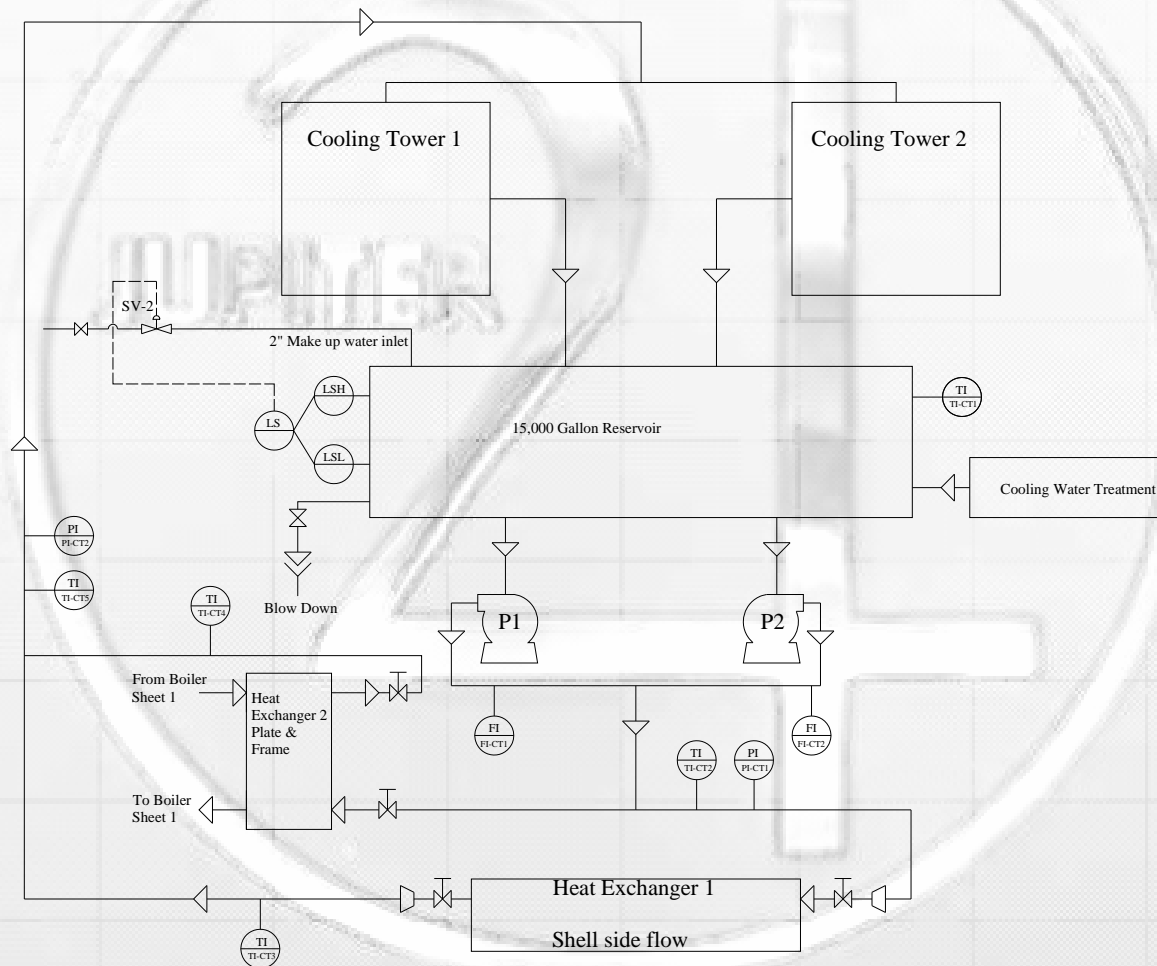

105 TPD Cryogenic Plant

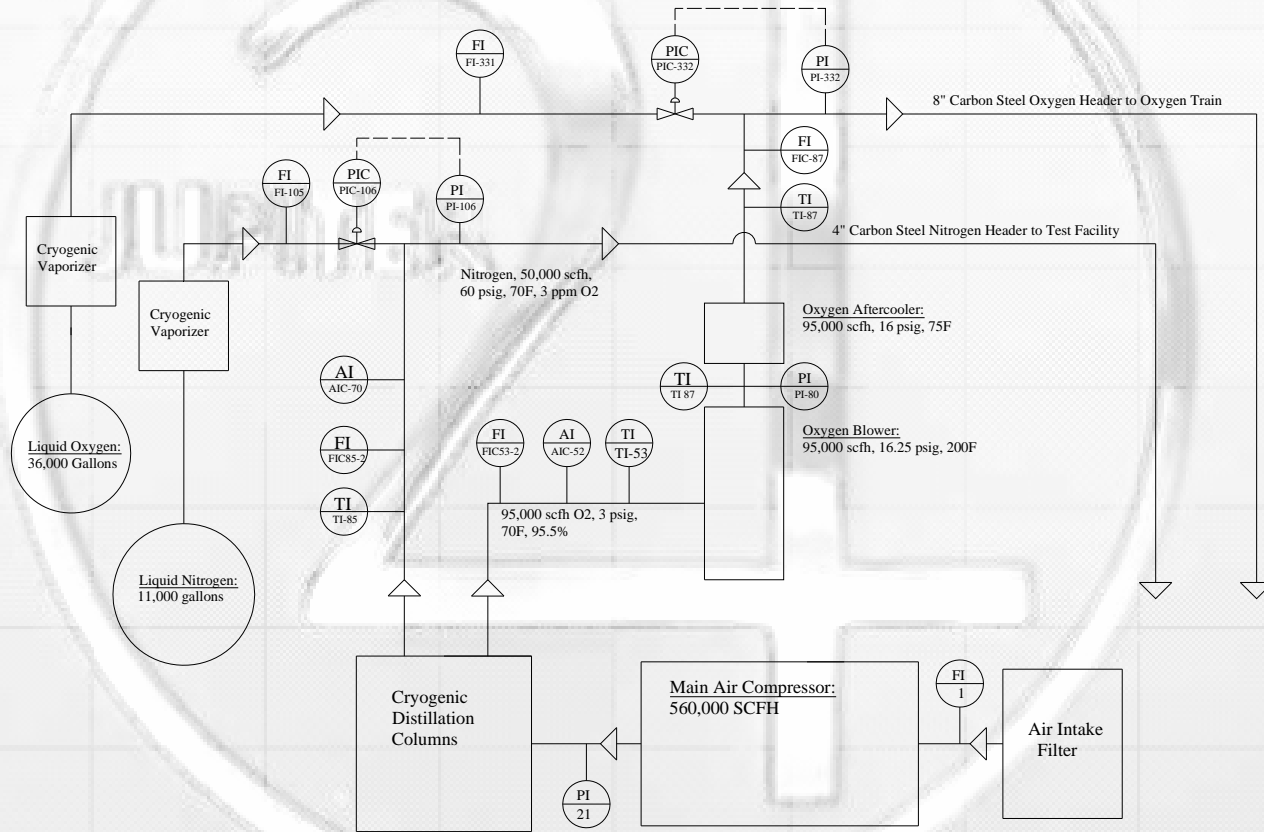

Oxygen Control

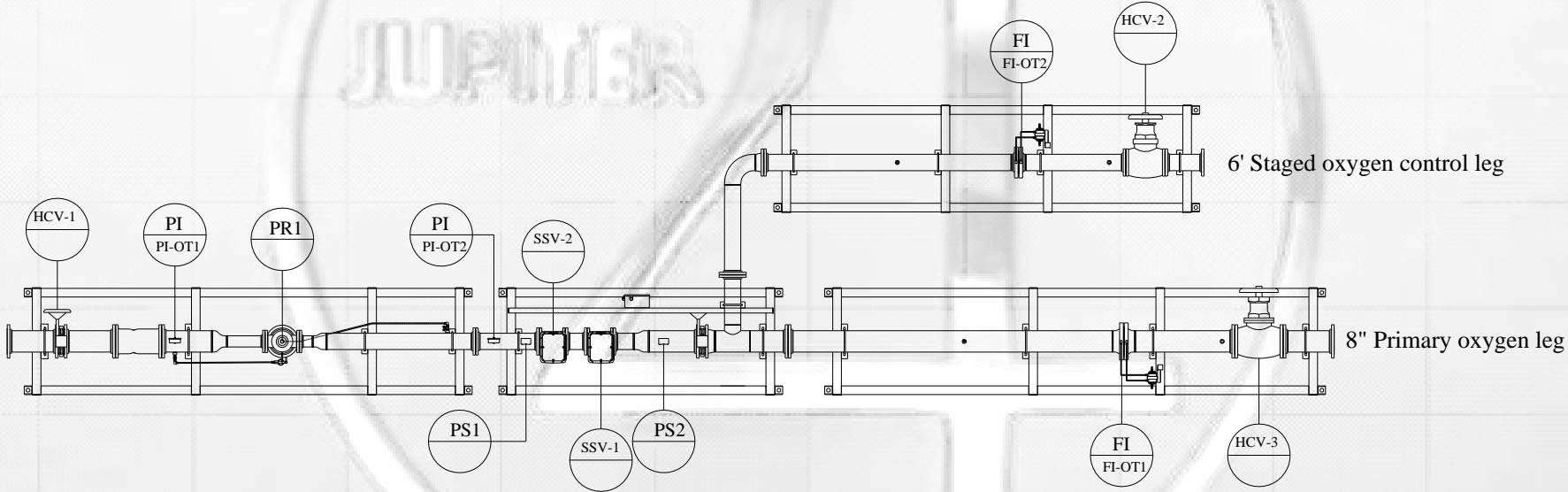

15 MWth Test Facility



Heat Transfer

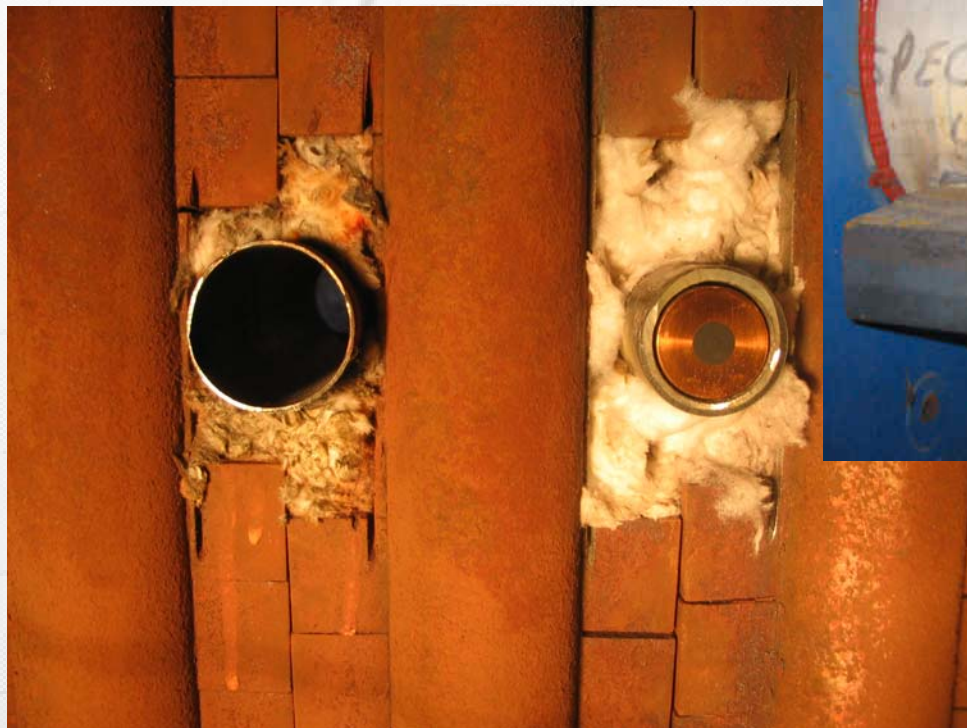

Project Participants



- **Jupiter Oxygen**
 - Construction of the test facility
 - Operation of the test facility
 - Technology provider for the Oxy-fuel
- **Doosan Babcock LLC**
 - Part of the data evaluation team
 - Slagging and fouling studies
- **USDOE – National Energy Technology Laboratory**
 - Integrated Pollutant Removal System
 - Data Collection design
 - Materials analysis
 - Final fate analysis
 - CO2 Quality
- **Maxon Corporation**
 - Supplier of oxy-fuel burner
 - Supplier of oxygen control systems
- **Coalteck LLC**
 - Consultant power generation
- **Michigan State**
 - High Temperature oxygen sensor
 - Material coupon analysis
- **Purdue University**
 - Heat Transfer Radiant versus Convective
 - Thermal Transfer modeling
 - Data reduction and Analysis
- **University of Wyoming**
 - Study on recycle with Wyoming coals



- **WEB:**
- www.jupiteroxygen.com

- **CONTACT US:**

- **Mark K. Schoenfield, Senior Vice President - Operations & General Counsel**
- Jupiter Oxygen Corporation
- 4825 N. Scott St., Suite 200, Schiller Park, IL 60176
- **PHONE:** 219 712 5206 **FAX:** 847 928 0795
- **EMAIL:** m_schoenfield@jupiteroxygen.com

- **Brian R. Patrick, Director of Development**
- Jupiter Oxygen Corporation
- 4825 N. Scott St., Suite 200, Schiller Park, IL 60176
- **PHONE:** 219 746 5586 **FAX:** 847 928 0795
- **EMAIL:** b_patrick@jupiteroxygen.com